

BUSHING HANDLES

QUICK-CHANGE HANDLE: ALUMINUM WITH 1144 STEEL UN-A-LOK LINER
 PERMANENT HANDLE: MILD STEEL

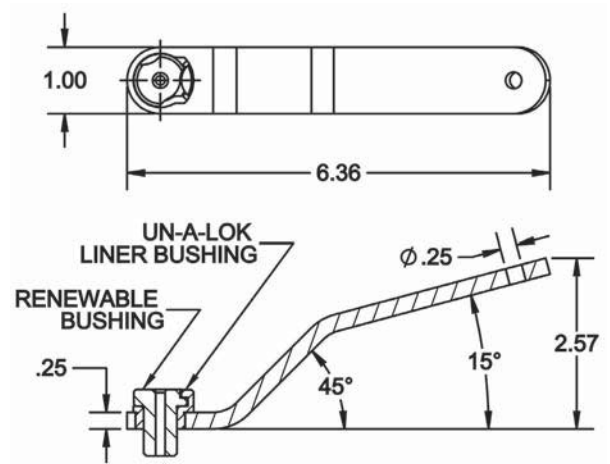

Quick-Change Bushing Handle



Quick-Change Bushing Handles are ready to hold any Slip/Fixed Renewable Drill Bushing in a choice of three OD sizes – 3/16, 5/16, or 1/2". These comfortable, high-quality handles provide convenient handling and extra support when using a portable drill motor. A Un-A-Lok liner bushing permanently installed in the handle provides excellent wear resistance and quick bushing changes. The handle is provided with a hole in the end for cable attachment. **Patent no. 11,235,450**

PART NO.	SF BUSHING OD
CL-12-BHQC	3/16
CL-20-BHQC	5/16
CL-32-BHQC	1/2



Permanent Bushing Handle

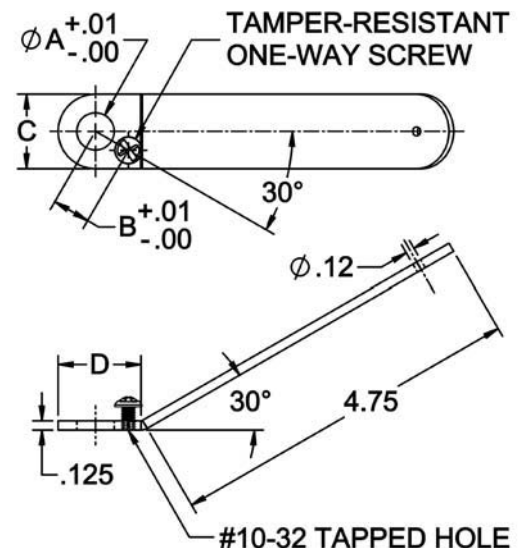

Permanent Bushing Handles are designed for one-time installation of a Slip/Fixed Bushing directly into the steel handle, where it is fastened with a tamper-resistant one-way screw to create a permanent assembly.

PART NO.	SF BUSHING OD	A DIA	B	C	D
CL-20-BH	5/16	.313	.383	1	1.12
CL-32-BH	1/2	.501	.508	1	1.12