

# FLOATING CLAMPS

HOUSING: ALUMINUM, ANODIZED GREEN.  
 BODY: STEEL, CASE HARDENED & NITRIDED, MANGANESE PHOSPHATE TREATED AND GROUND.  
 CLAMPING JAWS: STEEL, CASE HARDENED & NITRIDED, MANGANESE PHOSPHATE TREATED.



Floating Clamps are position-flexible clamping devices. The top jaw and bottom jaw together provide a floating clamping point that adjusts to the workpiece before locking, to prevent deformation. These combination clamp/supports are often used in conjunction with primary locators and clamps, providing additional support points to reduce machining vibration. Floating Clamps are especially useful for clamping forgings, ribbed or flanged castings, and other larger parts.

Install the clamp in a 1/2-13 threaded mounting hole by tightening using the body wrench flats. Adjust the height-limit stop and the swing range with the three setscrews in the green housing. When setting the height limit, consider the full range of workpiece tolerance.

To initiate clamping, push the Floating Clamp downward, then immediately swing the jaws into clamping position. The clamping jaws will automatically rise so that the bottom jaw contacts the workpiece with a light spring force. Next, tighten the top hex nut 11 ft-lbs minimum to 22 ft-lbs maximum, depending on the support load capacity desired. During the tightening process, the workpiece is clamped and simultaneously supported. Releasing is done in reverse order.

For more information and videos, see our online catalog at [carrlane.com](http://carrlane.com).

7

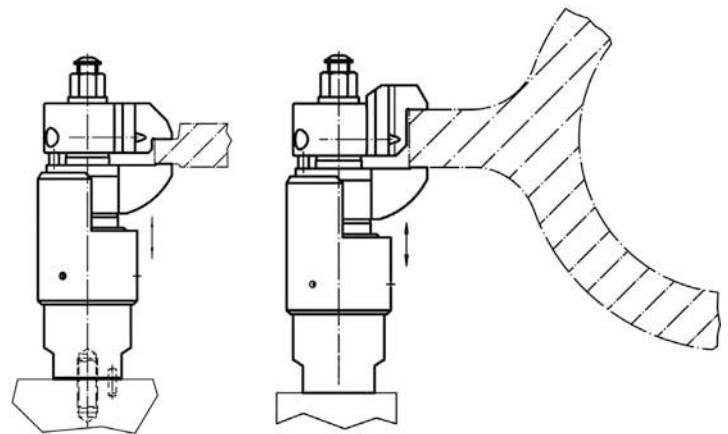
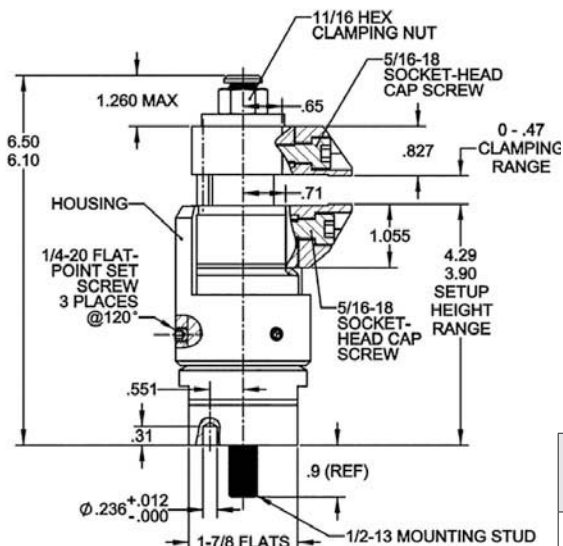
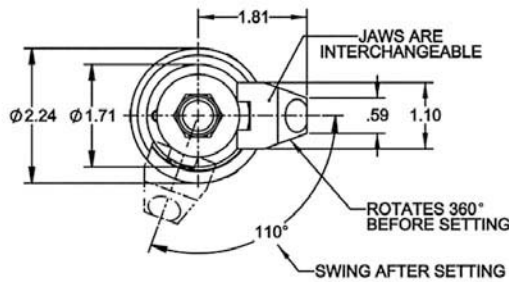

For custom applications, the standard upper clamping jaw supplied can be replaced by a special clamping jaw.

PART NO.	MOUNTING STUD	SUPPORT LOAD CAPACITY AT MINIMUM TIGHTENING TORQUE	SUPPORT LOAD CAPACITY AT MAXIMUM TIGHTENING TORQUE
CL-800-FLC	1/2-13	450 lbs @ 11 ft-lbs	1800 lbs @ 22 ft-lbs