

LOW PROFILE PIVOTING EDGE CLAMP

BODY AND JAW: 1018 STEEL, BLACK OXIDE
 EDGE GRIPPER: M-2 TOOL STEEL, HEAT TREATED RC 60-62, BLACK OXIDE
 DOWEL PIN: 4140 ALLOY STEEL



New item!

This edge clamp is well suited for holding medium to large castings and other moderate to tall workpieces. The pivoting jaw exerts clamping force forward and downward at the same time. The jaw has a replaceable serrated gripper made of hardened tool steel for high-production durability. The slotted base provides adjustability and has a tapered top surface to prevent the clamp from moving. Fasten with two Socket-Head Cap Screws.

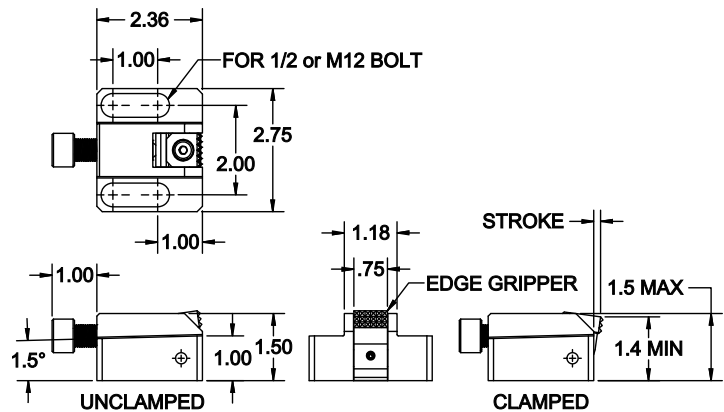

PART NO.	MAXIMUM CLAMPING STROKE	MOUNTING SCREW SIZE	THRUST SCREW SIZE	BALL-END THRUST SCREW (FURNISHED)	EDGE GRIPPER (FURNISHED)
CL-101-PEC	3/8	1/2-13 or M12	1/2-20	CL-80-BTS-1.75	CL-12-EG-6

HYDRAULIC CONVERSION ACCESSORIES

PART NO.	ITEM DESCRIPTION	MAXIMUM HYDRAULIC PRESSURE (psi)
CLR-802-TB	Hydraulic Threaded-Body Cylinder	7250
CLR-802-TBA	Hydraulic Feeder Cap	7250