

FLOATING LOCATING PINS

BODY: TOOL STEEL, HEAT TREATED, BLACK OXIDE FINISH

PIN: 1144 STEEL, HEAT TREATED, BLACK OXIDE FINISH



Provides precise location in one axis while allowing considerable float in the perpendicular axis. Use in conjunction with a Round Pin when loose workpiece-hole tolerances require more float than a Diamond Pin would allow. Special pin diameters (A dimensions) are available. Please contact factory.

Patent no. 3,381,554.

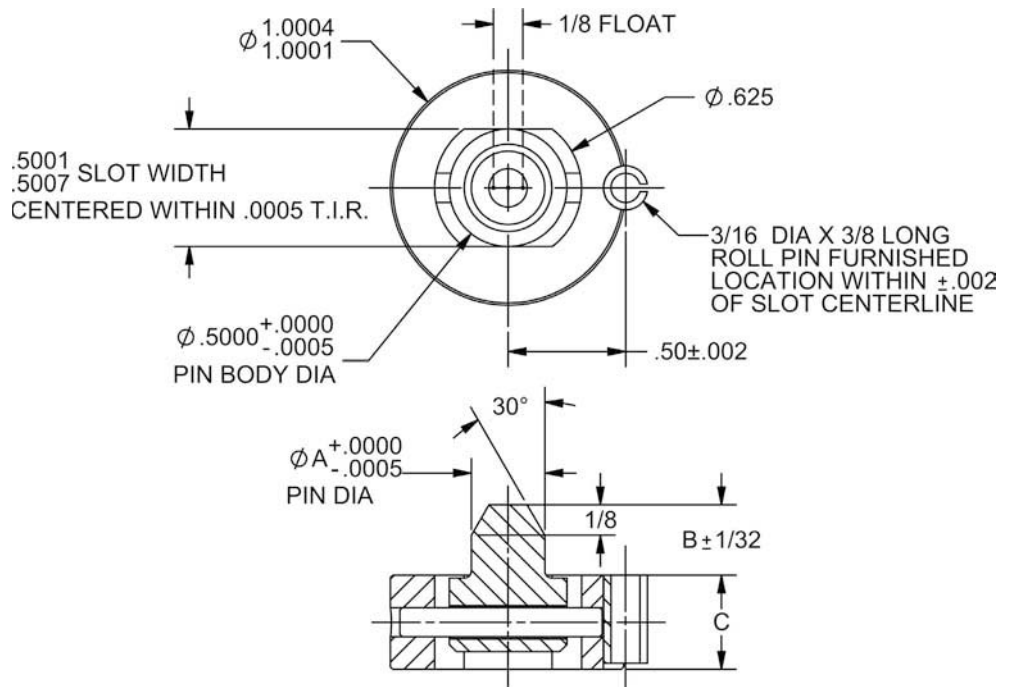
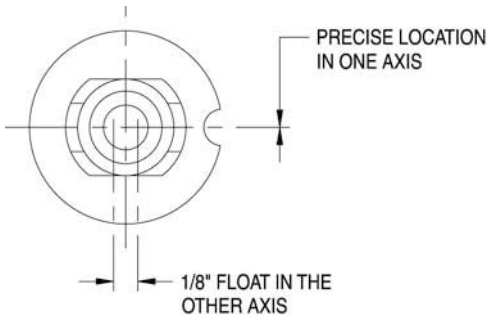
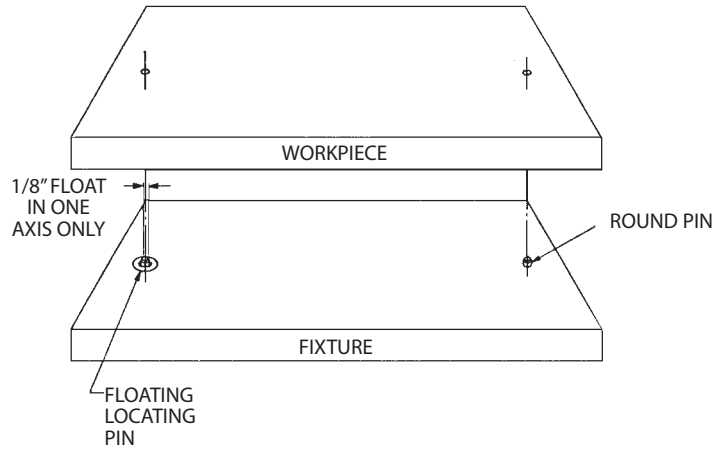

INCH

PART NO.	A DIA	B	C
CL-4-FLP	.2500	.300	.400
CL-5-FLP	.3125	.300	.400
CL-6-FLP	.3750	.300	.400
CL-8-FLP	.5000	.300	.400
CL-10-FLP	.6250	.310	.400