

SPRING STOP BUTTONS

BODY: ALUMINUM ALLOY; SPRING: SPRING STEEL
 PLUNGER: MILD STEEL, CASE HARDENED, ZINC PLATED CLEAR CHROMATE



Large
CL-30C-SSB



Medium
CL-20C-SSB



Small
CL-10C-SSB

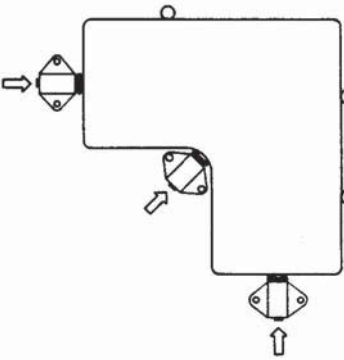

Spring Stop Buttons are ideal for holding a workpiece against its locators until clamps are in place, and for other light clamping jobs. Choice of three sizes in each type. The smallest of the three sizes is optionally available with light spring force.

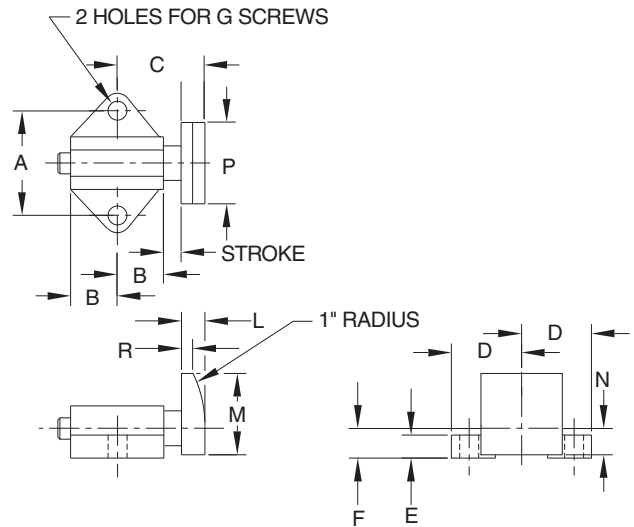

Type C
Flat Face

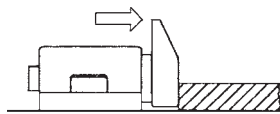

Flat contact surface is ideal for short workpieces.
 Large bevel on plunger makes loading easier.

TYPE C – FLAT FACE (STEEL)

PART NO. STANDARD FORCE	PART NO. LIGHT FORCE	STROKE	STANDARD CONTACT FORCE (LBS)			LIGHT CONTACT FORCE (LBS)			A	B	C	D	E	F	G DIA	K	L	M	N	P	R
			INITIAL	HALFWAY	FINAL	INITIAL	HALFWAY	FINAL													
CL-10C-SSB	CL-10C-SSB-2	1/8	5	10	15	1.5	2	2.5	.656	11/32	21/32	7/16	3/16	7/32	#5 or M3	—	3/16	5/8	3/16	5/8	1/16
CL-20C-SSB	—	3/16	2	14	26	—	—	—	1.125	1/2	15/16	3/4	1/4	5/16	#10 or M5	—	1/4	7/8	9/32	7/8	3/32
CL-30C-SSB	—	1/4	16	32	48	—	—	—	1.500	11/16	1-5/16	1	1/4	7/16	1/4 or M6	—	3/8	1-1/4	13/32	1-1/4	3/32