

STRAIGHT INDEX PLUNGERS

PLUNGER, BODY, CAM, AND BUSHING: 1144 STEEL, HEAT TREATED. CENTER SHAFT: 1144 STEEL. SPRING: MUSIC WIRE.
BALL KNOB: BLACK PHENOLIC PLASTIC WITH MOLDED-IN BRASS INSERT

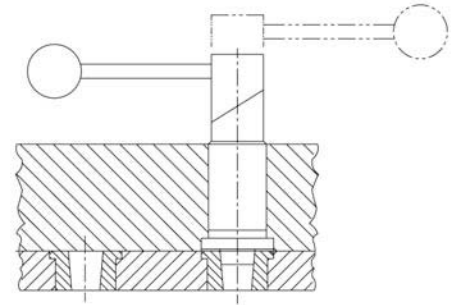

**Straight Index Plungers
Rotary Cam
Standard Mount**



Index Plungers are precision, heavy-duty assemblies with a retractable spring-loaded plunger and a matching locating bushing. Tapered Index Plungers feature a 15° taper on the plunger tip with a mating taper on the bushing. The taper makes alignment easier and also eliminates any binding during retraction. Straight Index Plungers have an entirely cylindrical plunger with a slight radius at the tip, used together with a straight bushing. A straight plunger provides slightly greater positional accuracy. Order plunger and bushing separately.

The rotary-cam version completely retracts when the handle is rotated 180°. Cam surfaces are hardened steel. The standard-mount configuration has a precision ground body with a whistle notch for orientation with a setscrew (also available with a slightly oversized unground body to allow custom grinding to size). Index Plungers are manufactured with precision working tolerances and are designed for very light interference-fit installations to avoid binding of the mechanism. Set screws with nylon tip inserts are recommended. Set screws should firmly contact the whistle notch, but not exert significant force.

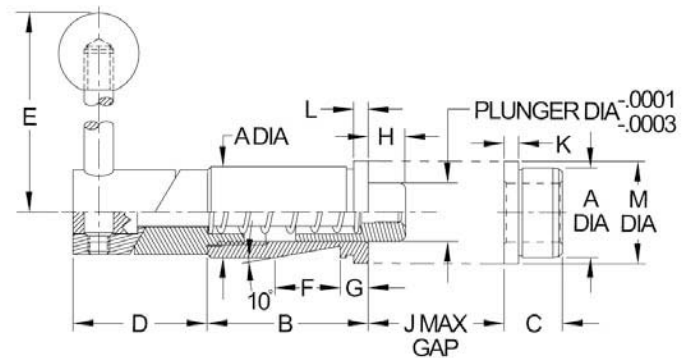

STRAIGHT INDEX PLUNGERS — ROTARY CAM, STANDARD MOUNT (INCH)

PART NO. INDEX PLUNGER	PART NO. BUSHING	PLUNGER DIA	A DIA			B	C	D	E	F	G	H	J	L	M DIA
			NOMINAL	GROUND	UNGROUND										
CL-22006-SIP	CL-22028-SIPB	1/2	3/4	.7518/.7515	—	1-3/8	1/2	1-1/8	3	7/16	5/16	5/16	3/32	1/8	7/8
CL-22004-SIP	CL-22026-SIPB			.766/.765											
CL-22106-SIP	CL-22128-SIPB	3/4	1-1/8	1.1268/1.1265	—	2	5/8	1-1/2	3-1/2	9/16	3/8	13/32	1/8	1/8	1-1/4
CL-22104-SIP	CL-22126-SIPB			1.141/1.140											
CL-22206-SIP	CL-22228-SIPB	1	1-1/2	1.5021/1.5018	—	2-1/4	3/4	1-7/8	4-1/2	11/16	7/16	7/16	1/8	1/8	1-5/8
CL-22204-SIP	CL-22226-SIPB			1.516/1.515											

STRAIGHT INDEX PLUNGERS — ROTARY CAM, STANDARD MOUNT (METRIC)

PART NO.	PLUNGER DIA (mm)	A DIA NOMINAL (mm)	A DIA ACTUAL (mm)	B (mm)	D (mm)	E (mm)	F (mm)	G (mm)	H (mm)	J (mm)	L (mm)	M DIA (mm)
CLM-22006-SIP	12	20	20.046 / 20.038 (Ground)	35	28.5	76	11	8	8	2.4	3	22
CLM-22106-SIP	20	30	30.046 / 30.038 (Ground)	51	38	89	14	9.5	10.5	3.2	3	32