

HAND-RETRACTABLE PLUNGERS

KNOB: MATTE BLACK FIBER-REINFORCED NYLON THERMOPLASTIC

PLUNGER: STEEL, HEAT TREATED

BODY PLATE: STEEL, ZINC PLATED CLEAR CHROMATE



**Knob Handle
with Mounting Plate
(Locking Type)**

**Knob Handle
with Mounting Plate
(Non-Locking Type)**

Precision indexing plunger with an attractive knob handle for convenient retraction. Mounting-plate version installs in a fixed position with two flat-head screws, and is available with either a short or long plunger extension. High strength and durability in an extremely compact assembly. Hardened and ground plunger tip has a slight taper for easy alignment. Available in two types, locking and non-locking, each with a choice of short or long plunger extension.

Locking type has a spring-loaded plunger that locks in retracted position. To lock, pull knurled knob back and turn 90°. The body is notched at 90° to keep the knob in its retracted position.

Non-locking type has a spring-loaded plunger that stays extended by spring force except when manually held in retracted position.

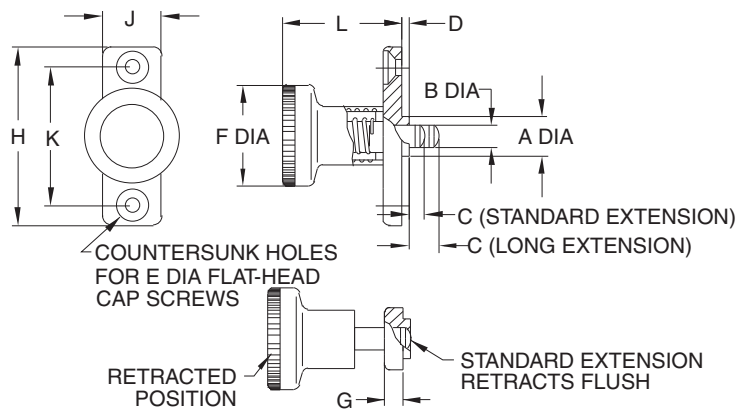

**Locking
and
Non-Locking**

LOCKING TYPE

PART NO. STANDARD EXTENSION	PART NO. LONG EXTENSION	A DIA		B DIA		C		D	E DIA	F DIA	G	H	J	K	L	END FORCE (LBS)	
		NOMINAL	ACTUAL	NOMINAL	ACTUAL	STANDARD EXTENSION	LONG EXTENSION									INITIAL	FINAL
CL-8-HRPM-L	CL-8-HRPM-LE	10mm	.393/.390	6mm	.2354/.2346	.24	.55 (24 stroke)	.10	#8 or M4	.98	.18	1.57	.71	1.181	1.12	1.9	4.9
CL-10-HRPM-L	CL-10-HRPM-LE	12mm	.472/.468	8mm	.3142/.3134	.31	.71 (31 stroke)		#10 or M5	1.22	.22	1.81	.79	1.339	1.32	3.5	6.3

NON-LOCKING TYPE

CL-8-HRPM-N	CL-8-HRPM-NE	10mm	.393/.390	6mm	.2354/.2346	.24	.55 (24 stroke)	.10	#8 or M4	.98	.18	1.57	.71	1.181	1.12	1.9	4.9
CL-10-HRPM-N	CL-10-HRPM-NE	12mm	.472/.468	8mm	.3142/.3134	.31	.71 (31 stroke)		#10 or M5	1.22	.22	1.81	.79	1.339	1.32	3.5	6.3