

BALL DETENTS

440C STAINLESS STEEL, HEAT TREATED

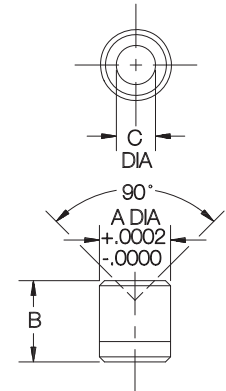
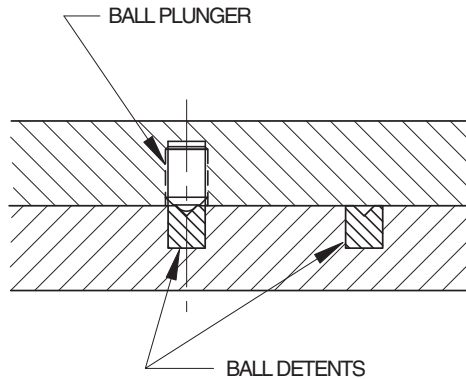

Press-in receptacle that provides a perfect mating hole for a Ball Plunger. Hole has a 90° point for smooth detent action and reliable retention. These hardened Ball Detents resist side loads to prevent wear to the parent material. Available in sizes to fit all Ball Plungers, from #4-48 to 5/8-11 (M4 to M12 in metric).

PART NO.	FOR BALL PLUNGER	A DIA	B	C DIA
CL-1-BD	#4-48, #5-40, M3	.1075	1/8	.056
CL-2-BD	#6-40	.1175	1/8	.061
CL-3-BD	#8-32, #8-36, #10-32, M4, M5	.1614	3/16	.082
CL-4-BD	1/4-20, M6	.2034	1/4	.111
CL-5-BD	5/16-18, M8	.2659	5/16	.139
CL-6-BD	3/8-16, M10	.3284	3/8	.164
CL-8-BD	1/2-13, M12	.4378	1/2	.241
CL-10-BD	5/8-11, M16	.5472	5/8	.330

PLUNGER WRENCHES

STEEL

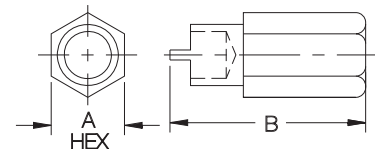
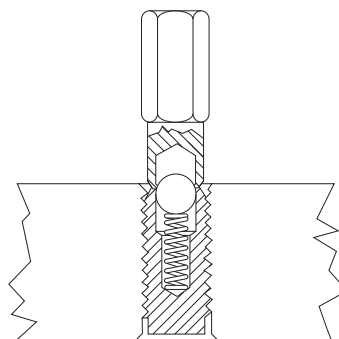

Handy tool to speed up installation of Ball Plungers or Spring Plungers. Much better than using a screwdriver on the ball/nose end, because the clearance hole in the center prevents over-compressing the plunger's internal spring. Available in sizes to fit all Ball Plungers and Spring Plungers, from #4-48 to 1"-8 (M4 to M12 in metric).

PART NO.	FITS THESE PLUNGER SIZES	A	B
CL-2-SPW	#4-48, #5-40, #6-32, #6-40	1/4	7/8
CL-4-SPW	#8-32, #8-36, M4	1/4	7/8
CL-6-SPW	#10-32, M5	1/4	7/8
CL-8-SPW	1/4-20, 1/4-28, M6	1/4	1
CL-10-SPW	5/16-18, M8	3/8	1
CL-12-SPW	3/8-16, M10	3/8	1
CL-14-SPW	1/2-13, M12	1/2	1
CL-16-SPW	5/8-11	5/8	1-1/8
CL-18-SPW	3/4-10	3/4	1-1/8
CL-20-SPW	1"-8	7/8	1-3/8