

# SWIVEL HEAD SCREWS

BODY: 1215 STEEL, CARBURIZED-HARDENED, ZINC PLATED YELLOW CHROMATE (OR 300-SERIES STAINLESS STEEL)

FOOT: 1215 STEEL, ZINC PLATED YELLOW CHROMATE (OR 300-SERIES STAINLESS STEEL, OR DELRIN®)

The steel version is optionally available with a black oxide finish by adding "-BO" to the part number (example: CL-1-SHS-BO). Type A and B feet are optionally available in Delrin® by adding "N" to the part number (examples: CL-1-SHSN, CL-1-SHS-BON, CL-1-SHS-SN).

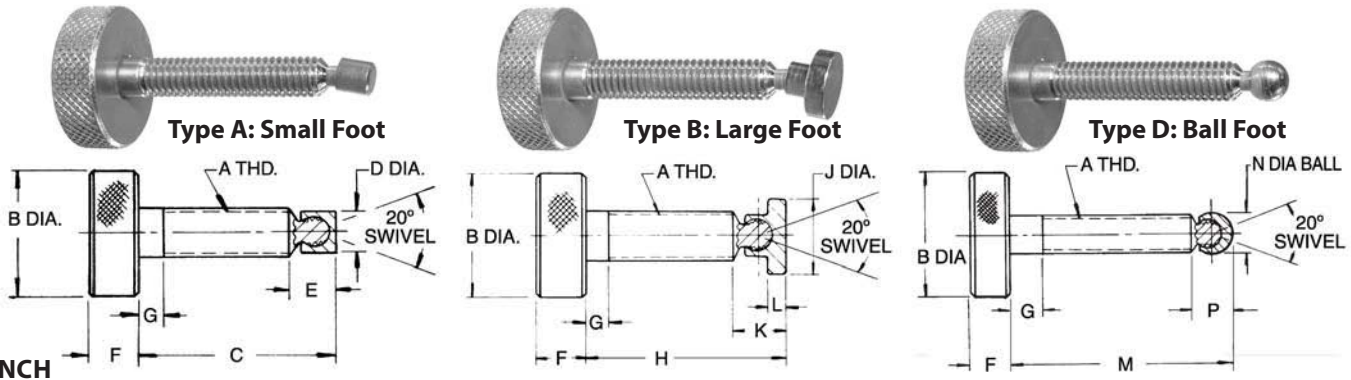

TYPE A STEEL PART NO.*	TYPE A STAINLESS PART NO.	TYPE B STEEL PART NO.*	TYPE B STAINLESS PART NO.	TYPE D STEEL PART NO.*	A	B DIA	C	D DIA	E	F	G	H	J DIA	K	L	M	N	P
CL-1-SHS	CL-1-SHS-S	CL-17-SHS	CL-17-SHS-S	CL-47-SHS	1/4-20	1	1	3/16	9/32	5/16	1/8	1-3/32	3/8	23/64	1/8	1-1/32	1/4	5/16
CL-2-SHS	CL-2-SHS-S	CL-18-SHS	CL-18-SHS-S	CL-48-SHS			1-1/2					1-17/32						
CL-3-SHS	CL-3-SHS-S	CL-19-SHS	CL-19-SHS-S	CL-49-SHS			2					2-3/32						
CL-33-SHS	CL-33-SHS-S	CL-40-SHS	CL-40-SHS-S	CL-50-SHS			3					3-3/32						
CL-4-SHS	—	CL-20-SHS	—	CL-51-SHS	5/16-18	1-1/8	1	1/4	11/32	3/8	3/16	1-3/32	1/2	27/64	5/32	1-1/64	5/16	23/64
CL-5-SHS	CL-5-SHS-S	CL-21-SHS	CL-21-SHS-S	CL-52-SHS			1-1/2					1-33/64						
CL-6-SHS	CL-6-SHS-S	CL-22-SHS	CL-22-SHS-S	CL-53-SHS			2					2-1/64						
CL-34-SHS	CL-34-SHS-S	CL-41-SHS	CL-41-SHS-S	CL-54-SHS			3					3-1/64						
CL-8-SHS	—	CL-24-SHS	—	CL-56-SHS	3/8-16	1-1/4	1-1/2	19/64	3/8	7/16	3/16	1-5/8	9/16	5/8	3/16	1-9/16	3/8	7/16
CL-9-SHS	CL-9-SHS-S	CL-25-SHS	CL-25-SHS-S	CL-57-SHS			2					2-1/16						
CL-35-SHS	CL-35-SHS-S	CL-42-SHS	CL-42-SHS-S	CL-58-SHS			3					3-1/8						
CL-36-SHS	CL-36-SHS-S	CL-43-SHS	CL-43-SHS-S	CL-59-SHS			4					4-1/8						
CL-11-SHS	—	CL-27-SHS	—	CL-61-SHS	1/2-13	1-1/4	1-1/2	13/32	15/32	1/2	3/16	1-9/16	3/4	17/32	3/16	1-19/32	1/2	9/16
CL-12-SHS	—	CL-28-SHS	—	CL-62-SHS			2					2-3/32						
CL-13-SHS	CL-13-SHS-S	CL-29-SHS	CL-29-SHS-S	CL-63-SHS			3					3-3/32						
CL-37-SHS	CL-37-SHS-S	CL-44-SHS	CL-44-SHS-S	CL-64-SHS			4					4-3/32						
CL-15-SHS	—	CL-31-SHS	—	CL-66-SHS	5/8-11	1-1/4	2	1/2	5/8	1/2	3/16	2-3/64	15/16	21/32	7/32	2-1/8	5/8	11/16
CL-16-SHS	—	CL-32-SHS	—	CL-67-SHS			3					3-1/8						
CL-38-SHS	—	CL-45-SHS	—	CL-68-SHS			4					4-1/8						
CL-39-SHS	—	CL-46-SHS	—	CL-69-SHS			5					5-1/8						

## METRIC

CLM-1-SHS-BO	—	CLM-17A-SHS-BO	—	CLM-47-SHS-BO	M6	1	.98	3/16	9/32	5/16	1/8	1.08	3/8	23/64	1/8	1.03	1/4	5/16
CLM-2-SHS-BO	—	CLM-18A-SHS-BO	—	CLM-48-SHS-BO			1.57					1.67						
CLM-3-SHS-BO	—	CLM-19-SHS-BO	—	CLM-49-SHS-BO			1.97					2.07						
CLM-4-SHS-BO	—	CLM-40-SHS-BO	—	CLM-50-SHS-BO			2.95					3.05						
CLM-5-SHS-BO	—	CLM-20-SHS-BO	—	CLM-51-SHS-BO	M8	1-1/8	.98	1/4	11/32	3/8	3/16	1.08	1/2	27/64	5/32	1.05	5/16	23/64
CLM-6-SHS-BO	—	CLM-21-SHS-BO	—	CLM-52-SHS-BO			1.57					1.67						
CLM-7-SHS-BO	—	CLM-22-SHS-BO	—	CLM-53-SHS-BO			1.97					2.06						
CLM-8-SHS-BO	—	CLM-41-SHS-BO	—	CLM-54-SHS-BO			2.95					3.05						
CLM-9-SHS-BO	—	CLM-24-SHS-BO	—	CLM-56-SHS-BO	M10	1-1/4	1.57	19/64	3/8	7/16	3/16	1.70	9/16	5/8	3/16	1.61	3/8	7/16
CLM-10-SHS-BO	—	CLM-25-SHS-BO	—	CLM-57-SHS-BO			1.97					2.10						
CLM-11-SHS-BO	—	CLM-42-SHS-BO	—	CLM-58-SHS-BO			2.95					3.08						
CLM-12-SHS-BO	—	CLM-43-SHS-BO	—	CLM-59-SHS-BO			3.94					4.06						
CLM-11A-SHS-BO	—	CLM-27-SHS-BO	—	CLM-61-SHS-BO	M12	1-1/4	1.57	13/32	15/32	1/2	3/16	1.64	3/4	17/32	3/16	1.69	1/2	9/16
CLM-12A-SHS-BO	—	CLM-28-SHS-BO	—	CLM-62-SHS-BO			1.97					2.03						
CLM-13-SHS-BO	—	CLM-29-SHS-BO	—	CLM-63-SHS-BO			2.95					3.01						
CLM-14-SHS-BO	—	CLM-44-SHS-BO	—	CLM-64-SHS-BO			3.94					4.00						
CLM-15-SHS-BO	—	CLM-31-SHS-BO	—	CLM-66-SHS-BO	M16	1-1/4	1.97	1/2	5/8	1/2	3/16	2.01	15/16	21/32	7/32	2.06	5/8	11/16
CLM-16-SHS-BO	—	CLM-32-SHS-BO	—	CLM-67-SHS-BO			2.95					3.00						
CLM-17-SHS-BO	—	CLM-45-SHS-BO	—	CLM-68-SHS-BO			3.94					3.98						
CLM-18-SHS-BO	—	CLM-46-SHS-BO	—	CLM-69-SHS-BO			4.92					4.97						

\* Inch sizes are available zinc plated or with black oxide finish. Metric sizes are available only with black oxide finish (-BO only).