

HEAVY-DUTY® SWIVEL HOIST RINGS

4140 STEEL, HEAT TREATED, BLACK OXIDE FINISH, 100% MAGNAFLUX INSPECTED



The next generation of Swivel Hoist Rings, with a heavy-duty forged steel ring. Pivots 180 degrees and swivels 360 degrees simultaneously to allow lifting from any direction. Safety factor = 5:1. Meets OSHA standards and Military Specification MIL-STD-1365(11) or MIL-STD-209C. **Patent no. 4,570,987 and 4,641,986, and other patents pending.**

Fasten hoist rings using the installation torque specified in the dimension table. Always install so that the hoist ring can pivot and swivel freely. Some hoist rings are available with a choice of bolt lengths. Use the shortest bolt length only for steel plates, the other lengths for weaker materials and for through-hole mounting with a washer and nut. **INFO+:** See general Hoist Ring Safety Precautions on page 71.

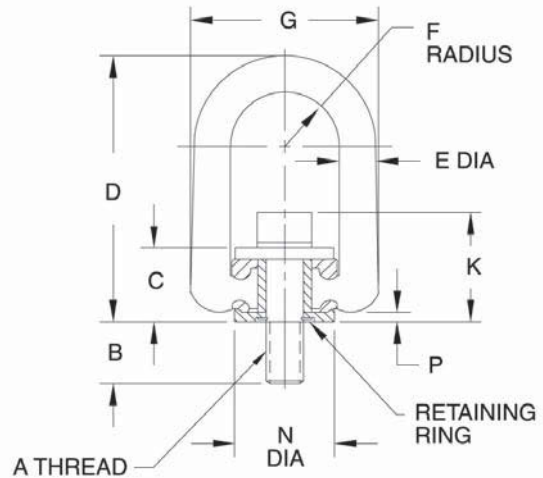
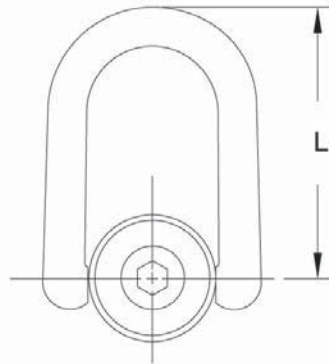

STANDARD RING (INCH)

PART NO.	LOAD RATING (LBS)	A	B	C	D	E DIA	F	G	K	L	N DIA	P	INSTALLATION TORQUE (FT-LBS)	REPLACEMENT BOLT (WITH RETAINING RING)
CL-33106-SHR	10000	1"-8	1.20	2.05	7.37	1.00	1.40	5.10	3.05	6.62	2.81	.18	230	CL-33126-SHRB
CL-33105-SHR			1.45											CL-33125-SHRB
CL-33107-SHR			2.20											CL-33127-SHRB
CL-33402-SHR	15000	1-1/4"-7	1.88	2.87	9.22	1.25	2.00	6.75	4.23	8.12	3.88	.32	470	CL-33419-SHRB
CL-33401-SHR			2.63											CL-33421-SHRB
CL-33420-SHR	20000	1-3/8"-6	2.63	2.87	9.22	1.25	2.00	6.75	4.35	8.12	3.88	.32	670	CL-33429-SHRB
CL-33424-SHR	24000	1-1/2"-6	2.63	2.87	9.22	1.25	2.00	6.75	4.48	8.12	3.88	.32	800	CL-33422-SHRB
CL-33427-SHR	30000	2"-4-1/2	2.96	2.87	9.22	1.25	2.00	6.75	4.48	8.12	3.88	.32	1100	—
CL-33432-SHR		2"-8												—

STANDARD RING (METRIC)

PART NO.	LOAD RATING (kg)	A THREAD	THREAD PITCH (mm)	B (mm)	C (mm)	D (mm)	E DIA (mm)	F (mm)	G (mm)	K (mm)	L (mm)	N DIA (mm)	P (mm)	INSTALLATION TORQUE (Nm)	REPLACEMENT BOLT (WITH RETAINING RING)
CLM-34401-SHR	7000	M30	3.5	67	73	234	32	51	171.5	107.5	206	98.5	8.2	640	CLM-34421-SHRB
CLM-34402-SHR	11000	M36	4	67	73	234	32	51	171.5	114	206	98.5	8.2	1090	CLM-34422-SHRB
CLM-34403-SHR	12500	M42	4.5	80	73	234	32	51	171.5	114	206	98.5	8.2	1090	CLM-24232-SHRB
CLM-34404-SHR	13500	M48	5	80	73	234	32	51	171.5	114	206	98.5	8.2	1090	CLM-24225-SHRB