

CAPTIVE JIG PINS

PIN: 1215 STEEL, HEAT TREATED, BLACK OXIDE FINISH
 HANDLE: SPRING STEEL, BLACK OXIDE FINISH
 BUSHING: 1144 STEEL, CASE HARDENED, BLACK OXIDE FINISH

1



Similar to a standard Jig Pin, except that the pin body is positively retained in a locking bushing. In fully retracted position, the bushing's spring clip snaps into the pin's groove. This holds the pin fully retracted by spring force and positively prevents removal. Spring pressure also holds the pin in intermediate extended positions, an advantage especially if the fixture is turned upside down. Like standard Jig Pins, Captive Jig pins have an integral shoulder to keep the handle raised. Available in pin diameters from 3/16 to 1/2". Made in USA.

Locking-Pin Bushings are designed to press fit in a standard reamed hole. Secure with the included Lockscrew to positively hold the bushing in place. Shorter or longer bushings are available in most sizes, for thinner or thicker plates.

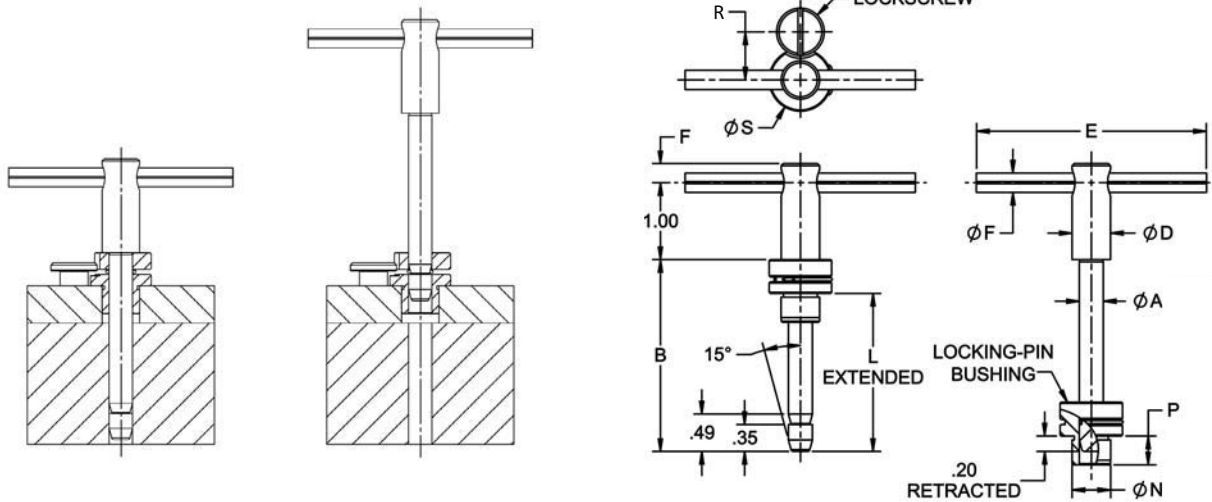

COMPLETE ASSEMBLY (INCH)

PART NO.	A DIA		B PIN LENGTH	P BUSHING LENGTH UNDER HEAD		D DIA	E	F	G	H	J	L	M	N DIA		R	S DIA	JIG PIN (INCLUDED)	BUSHING (INCLUDED)	LOCKSCREW (INCLUDED)
	NOMINAL	ACTUAL +.0000/- .0005		NOMINAL	ACTUAL +.0000/- .0003									+ .03/- .01						
CL-1-CJPA	3/16	.1865	1-7/8	Standard	.31	3/8	2	3/16	.49	1	.35	1.40	.20	13/32	.4078	.62	13/16	CL-1-CJP	CL-3-LPB	LS-1
CL-2-CJPA	1/4	.2490	2	Standard	.31	3/8	2	3/16	.49	1	.35	1.60	.20	13/32	.4078	.62	13/16	CL-2-CJP	CL-4-LPB	LS-1
CL-21-CJPA				Long	.50														CL-4A-LPB	
CL-31-CJPA	5/16	.3115	2-1/2	Standard	.31	1/2	3	1/4	.49	1	.35	2.10	.20	1/2	.5017	.62	13/16	CL-3-CJP	CL-5-LPB	LS-1
CL-3-CJPA				Medium	.37														CL-5A-LPB	
CL-33-CJPA				Long	.50														CL-5B-LPB	
CL-41-CJPA	3/8	.3740	3-1/4	Standard	.31	1/2	3	1/4	.49	1	.35	2.80	.20	5/8	.6267	.62	13/16	CL-4-CJP	CL-6-LPB	LS-1
CL-4-CJPA				Long	.50														CL-6A-LPB	
CL-51-CJPA	1/2	.4990	4	Standard	.50	9/16	3	1/4	.49	1	.35	3.60	.20	3/4	.7518	.75	1-1/16	CL-5-CJP	CL-8-LPB	LS-1
CL-5-CJPA				Long	.75														CL-8A-LPB	