

# JIG PINS

PIN: 1144 STEEL, HEAT TREATED, BLACK OXIDE FINISH  
HANDLE: SPRING STEEL, BLACK OXIDE FINISH

1

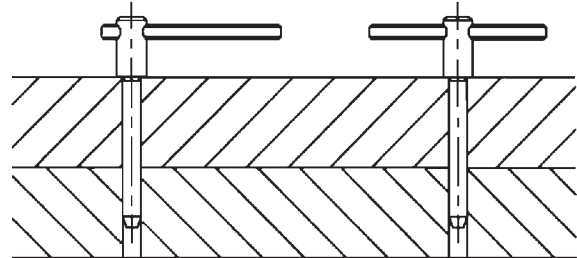

Similar to L and T Pins, but with a shoulder to keep the handle raised. Pins are ground slightly undersized. To convert from an L handle to a T handle, slide the roll-pin handle by tapping it with a hammer.

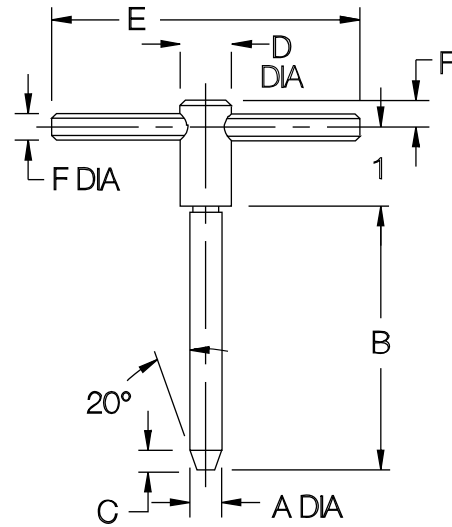

## INCH

PART NO.	A DIA		B	C	D DIA	E	F
	NOMINAL	ACTUAL +0/-0.0005					
CL-10-JP	3/16	.1872	1-7/8	1/8	3/8	2	3/16
CL-20-JP	1/4	.2497	2	5/32			
CL-30-JP	5/16	.3120	2-1/2	3/16	1/2	3	1/4
CL-40-JP	3/8	.3745	3-1/4	1/4			
CL-50-JP	1/2	.4995	4	9/32			

## METRIC

PART NO.	A DIA (mm)		B (mm)	C (mm)	D DIA (mm)	E (mm)	F (mm)
	NOMINAL	ACTUAL +0/-0.013					
CLM-6-JP	6	5.992	51	3.9	9.5	51	4.8
CLM-8-JP	8	7.988	63.5	4.8	12.5	76	6.5
CLM-10-JP	10	9.987	82.5	6.5	12.5	76	6.5
CLM-12-JP	12	11.986	101.5	7	14	76	6.5