

SERRATED EDGE CLAMPS

BODY AND NOSE: 1018 STEEL, CASE HARDENED, BLACK OXIDE FINISH
 CLAMPING SCREW: 4140 STEEL, HEAT TREATED RC 43-45, BLACK OXIDE FINISH
 NOSE COVER: ALUMINUM



Serrated Fixed Edge Clamp (High Nose)



Serrated Fixed Edge Clamp (Low Nose)

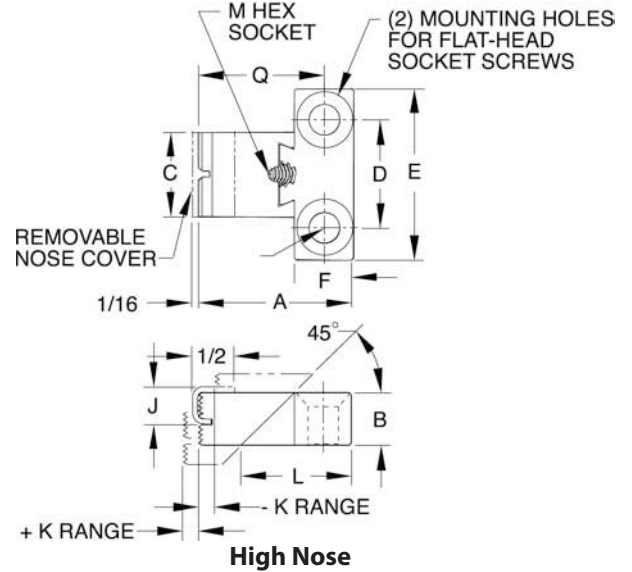

Serrated Fixed Edge Clamps mount in a fixed position, rather than having a slot for adjustment. This makes the clamps more compact and ensures that they are mounted in the correct location without requiring adjustment. The fixed version is usually better for permanent fixtures, while the adjustable version is better for machine-table mountings. The Flat-Head Socket Screws used for mounting absolutely hold proper location (order separately). Choice of three clamp sizes, with either a high nose or low nose.

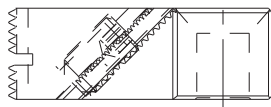

High Nose

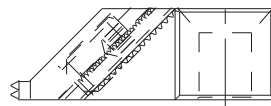

Low Nose

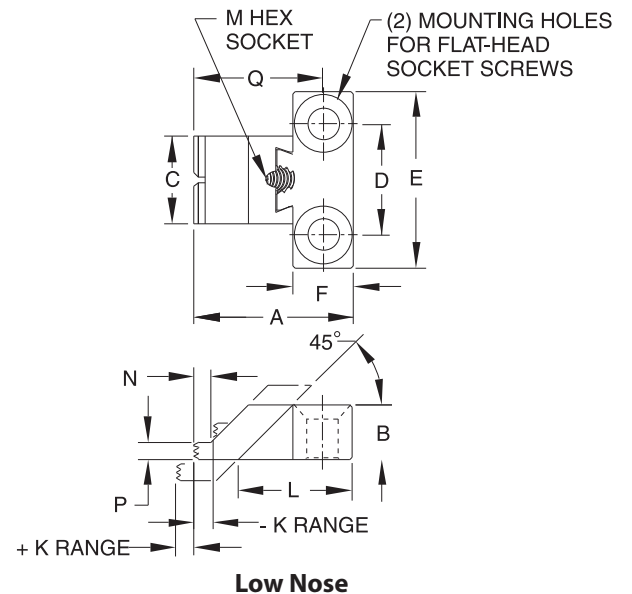

Low Nose

FIXED POSITION — HIGH NOSE

PART NO.	MOUNTING SCREW SIZE	A	B	C	D	E	F	J	K	L	M	N	P	Q
CL-5-SFC	5/16-18	1-27/32	5/8	1	1	1-3/4	11/16	7/16	1/4	1-5/16	5/32	—	—	1-1/2
CL-45-SFC	1/2-13	2-25/32	7/8	1-1/2	2	3	31/32	5/8	5/16	1-27/32	1/4	—	—	2-9/32
CL-75-SFC	5/8-11	3-7/16	1-1/4	1-3/4	2	3-1/4	1-1/4	3/4	5/16	2-1/2	5/16	—	—	2-13/16

FIXED POSITION — LOW NOSE

CL-0-SFC	5/16-18	1-27/32	5/8	1	1	1-3/4	11/16	—	1/4	1-5/16	5/32	1/8	1/8	1-1/2
CL-40-SFC	1/2-13	2-25/32	7/8	1-1/2	2	3	31/32	—	5/16	1-27/32	1/4	1/4	1/4	2-9/32
CL-70-SFC	5/8-11	3-7/16	1-1/4	1-3/4	2	3-1/4	1-1/4	—	5/16	2-1/2	5/16	5/16	3/8	2-13/16